

GME per misura fiscale

- Contatore completo e versatile per la misura dell'energia elettrica
- Contatore teleleggibile dal sistema centrale di acquisizione e validazione di ENEL distribuzione
- Contatore con requisiti funzionali idonei alle richieste tecniche di connessione attualmente in vigore (CEI-016)
- Contatore predisposto per la lettura da parte di sistemi esterno di acquisizione
- Contatori predisposti per l'invio e la sincronizzazione di segnali al sistema X-RWU, in applicazione GME
- Possibilità di integrazione modem GSM/GPRS

ZMD 410 CT

ZMD405AT/CT, ZFD405AT/CT, ZMD410AT/CT, ZFD410AT/CT

E650 Series 3

E650 Series 3 ZxD400AT/CT – Technical specifications



General

Voltage

Nominal voltage U_n ZMD400xT

3 x 58/100 V to 69/120 V
3 x 110/190 V to 133/230 V
3 x 220/380 V to 240/415 V

Extended operating voltage range

3 x 58/100 to 240/415 V

Nominal Voltage U_n ZFD400xT

3 x 100 to 120 V
3 x 220 to 240 V

Extended operating voltage range 3 x 100 to 415 V

Voltage range 80 to 115%

Frequency

Nominal frequency f_n 50 or 60 Hz

Tolerance 2%

IEC-specific data

Current

Nominal current I_n 1 A, 2 A, 5 A, 5||1 A

Maximal current I_{max}

Metrological 2 A, 5 A 200% I_n

Metrological 1 A 2 A, 10 A

Metrological 5||1 A 6 A

Thermal 1 A, 2 A, 5 A, 5||1 A 12 A

Short-circuit current 0.5 s with 20 x I_{max}

Measurement accuracy

ZxD405xT

Active energy, to IEC 62053-22 class 0.5 S

Reactive energy, to IEC 62053-23 accuracy 1%

ZxD410xT

Active energy, to IEC 62053-21 class 1

Reactive energy, to IEC 62053-23 accuracy 1%

Measurement behaviour

Starting current ZxD405xT

According to IEC 0.1% I_n

Typical 0.07% I_n

5||1 A as 1 A meter

Starting current ZxD410xT

According to IEC 0.2% I_n

Typical 0.14% I_n

5||1 A as 1 A meter

The start-up of the meter is controlled by the starting power and not by the starting current.

Starting power in M-circuit single phase

Nominal voltage x starting current

Starting power in F-circuit all phases

Nominal voltage x starting current x $\sqrt{3}$

MID-specific data

Current (for classes B and C)

Rated current I_n 1.0 A, 5.0 A

Minimum current I_{min} 0.01 A, 0.05 A

Transitional current I_{tr} 0.05 A, 0.25 A

Maximum current I_{max} 2.0 A, 10.0 A

Measurement accuracy to EN 50470-

ZxD400xT classes B and C

Measurement behaviour

Starting current I_{st}

Class B: I_{st} 0.002 A, 0.01

Class C: I_{st} A 0.001 A, 0.005 A

ZMD 410 CT



General

Operating behaviour

Voltage failure (power-down)

Bridging	0.5
time Data storage	s after another storage
Switch off	0.2 s after approx. 2.5 s

Voltage restoration (power-up)

Function standby 3 phases	after 2 s
Function standby 1 phase	after 5 s
Detection of energy direction and phase voltage	after 2 to 3 s

Power consumption

Power consumption per phase in voltage circuit

Phase voltage	58 V	100 V	240 V
Active power (typical)	0.4 W	0.5 W	0.7 W
Apparent power (typical)	0.8 VA	1.0 VA	1.7 VA

Power consumption per phase in current circuit

Phase current	1 A	5 A	10 A
Active power (typical)	5 mW	0.125 W	0.5 W
Apparent power (typical)	5 mVA	0.125 VA	0.5 VA

Environmental influences

Temperature range	to IEC 62052-11
Operation	-40 °C to +70 °C
Storage	-40 °C to +85 °C

Temperature coefficient

Range	-40 °C to +70 °C
Average value (typical)	0.012% per K
at cos = 1 (from 0.05 I _b to I _{max})	0.02% per K
at cos = 0.5 (from 0.1 I _b to I _{max})	0.03% per K

Impermeability to IEC 60529	IP51
-----------------------------	------

Electromagnetic compatibility

Electrostatic discharges	to IEC 61000-4-2
Contact discharge	15 kV

Immunity conducted disturbances	2 to 150 kHz
According to CENELEC	TR 50579

Electromagnetic RF fields	to IEC 61000-4-3
80 MHz to 2 GHz	10 and 30 V/m

Radio interference suppression according to IEC/CISPR 22	class B
--	---------

Fast transient burst test	to IEC 61000-4-4
---------------------------	------------------

Current and voltage circuits under load according to IEC 62053-21/23	4 kV
Auxiliary circuits > 40 V	2 kV

Fast transient surge test	to IEC 61000-4-5
---------------------------	------------------

Current and voltage circuits	4 kV
Auxiliary circuits > 40 V	1 kV

Insulation strength

Insulation strength	4 kV at 50 Hz during 1 min.
---------------------	-----------------------------

Impulse voltage 1.2/50 s	to IEC 62052-11
--------------------------	-----------------

Current and voltage circuits	8 kV
Auxiliary circuits	6 kV

Protection class II	to IEC 62052-11
---------------------	-----------------

Calendar clock

Calendar type	Gregorian or Persian (Jalaali)
---------------	--------------------------------

Accuracy	< 5 ppm
----------	---------

Backup time (power reserve) meter

With supercapacitor	> 20 days
Charging time for max. backup	300 h
time With battery (optional)	10 years
Battery type	CR-P2

Display

Characteristics

Type	LCD liquid crystal display
Digit size in value field	8 mm
Number of digits in value field	up to 8
Digit size in index field	6 mm
Number of digits in index field	up to 8

ZMD 410 CT

Inputs and outputs

Control inputs	
Control voltage	100 to 240 V _{AC}
U _S Input current	< 2 mA ohmic at 230 V _{AC}

Output contacts	
Type	solid-state relay
Voltage	12 to 240 V _{AC/DC}
Max. current	100 mA
Max. switching frequency (pulse length 20 ms)	25 Hz

Optical test outputs active and reactive energy	
Type	red LED
Number	2
Meter constant	selectable

Relay contacts on extension board 326x	
Type	relay
Voltage Max. current	240 V _{AC} 8 A
Max. operations with cos ϕ = 1	100 000 op.

Control inputs on extension board 326x	
Control voltage	12 to 24 V _{DC}
U _S Input current	< 6 mA ohmic at 24 V _{DC}

Communication interface

Optical interface to IEC 62056-21	
Type	serial, asynchronous, half-duplex
Max. transmission rate	9600 bps
Protocols	IEC 62056-21 and dlms

Communication units

Exchangeable communication units for various applications.

Additional power supply (optional)

On extension board 045x	
Nominal voltage range	100 to 240 V _{AC/DC}
Tolerance	80 to 115% U _n
Frequency	50 or 60 Hz
Max. power consumption	6.8 W

On extension board 046x and 326x	
Nominal voltage range	12 to 24 V _{DC}
Tolerance	80 to 115% U _n
Max. power consumption 046x	3.5 W
Max. power consumption 326x	5.5 W

On extension board 047x	
Nominal voltage range	12 to 60 V _{DC}
Tolerance	80 to 115% U _n
Max. power consumption	5.0 W

Weight and dimensions

Weight	approx. 1.5 kg
--------	----------------

External dimensions

Width	177 mm
Height (with short terminal cover)	244 mm
Height (with standard terminal cover)	281.5 mm
Height (with extended hook)	305.5 mm
Depth	75 mm

Suspension triangle

Height (with extended hook)	230 mm
Height (suspension eyelet open)	206 mm
Height (suspension eyelet covered)	190 mm
Width	150 mm

Terminal cover

Short	no free space
Standard (opaque, transparent)	40 mm free space
Long (opaque, transparent)	60 mm free space
GSM	60 mm free space
ZxB type 80 mm	80 mm free space
ZxB type 110 mm	110 mm free space
ADP2 adapter	

Material housing

Polycarbonate, partly glass-fibre reinforced

Environmental

RoHS compliant design

Connections

Phase connections	
Type	screw type terminals
Diameter	5.2 mm
Recommended conductor cross section	4 to 6 mm ²
Screw head dimensions	Screw Pozidrive Combi No. 2 M4 x 8
Screw head diameter	≤ 5.8 mm
Tightening torque	< 1.7 Nm

Other connections

Type	screwless spring-type terminal
Max. current of voltage outputs	1 A
Max. voltage of inputs	250 V

ZMD 410 CT

Terminal layout according to DIN

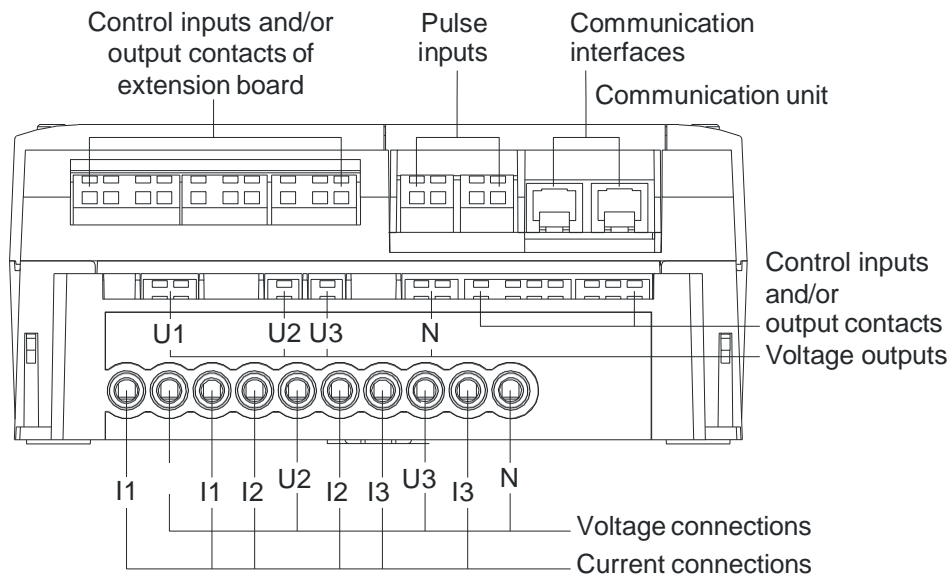

Symmetrical terminal layout (optional, ZMD400 only)

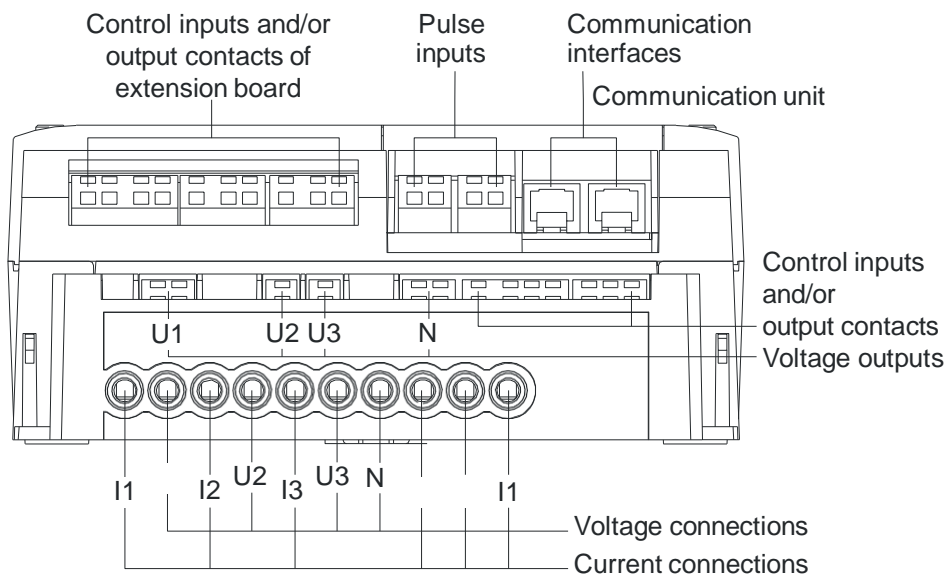

ZMD 410 CT

Type designation	ZMD	4	10	C	T	44	4207	S3
Network type								
ZFD	3-phase 3-wire network (F-circuit)							
ZMD	3-phase 4-wire network (M-circuit)							
Connection type								
4	Transformer operated							
Accuracy class								
10	Active energy class 1 (IEC), B (MID)							
05	Active energy class 0.5s (IEC), C (MID)							
Measured quantities								
C	Active and reactive energy							
A	Active energy							
Construction								
T	With exchangeable communication units							
Tariffication								
21	Energy rates, external rate control via control inputs							
24	Energy rates, internal rate control via time switch (additionally possible via control inputs)							
41	Energy and demand rates, external rate control via control inputs							
44	Energy and demand rates, internal rate control via time switch (additionally possible via control inputs)							
	All versions with 3 control inputs and 2 output contacts							
Additional functions								
000x	No extension board							
060x	6 outputs							
240x	2 control inputs, 4 outputs							
420x	4 control inputs, 2 outputs							
326x	3 control inputs, 2 relays outputs, auxiliary power supply 12 to 24 V _{DC}							
045x	4 outputs, auxiliary power supply 100 to 240 V _{AC} /V _{DC}							
046x	4 outputs, auxiliary power supply 12 to 24 V _{DC}							
047x	4 outputs, auxiliary power supply 12 to 60 V _{DC}							
xxx0	No additional functions							
xxx2	DC-magnet detection							
xxx7	Load profile							
xxx9	DC-magnet detection and load profile (integrated terminal cover switch option only available in this configuration)							
Series 3								

SL7000



Specifiche Tecniche

Valori Nominali	Tensione: Corrente Diretta: Corrente:	3*57.7/100V sino a 3*277/480V auto ranging In 5A, I _{max} 120A I _b 1A, I _{max} 10A
Tipi di inserzione	Inserzione Diretta: Inserzione su TA e TV:	4 fili operabile anche a 3 fili senza neutro 3 o 4fili
Precisione	Inserzione Diretta Inserzione su TA e TV: Energia reattiva:	Classe 1 o MID B Classe 0.2S, 0.5S o MID C Classe 1 o 2
Frequenza		50 / 60 Hz
Standards		IIEC 62052, IEC 62053, MID standard EN50470-1 ed EN50470-3 - CE standards (meccanici, climatici, elettrici, elettromeccanici, metrologici)
Comunicazione		Porta IR (IEC 61107), RS232C e/o RS485 Protocollo DLMS-Cosem (IEC 62056) Integrato in gran parte dei principali sistemi SW di lettura (AMR)

Accessori

Comunicazione	Modem esterni (es. Kit GSM Telemetry Itron) Modem Sparklet Itron, alimentati dal contatore, alloggiabili sotto al coprimorsetti Connessioni per dispositivi esterni Sonda ottica per lettura porta IR da PC
Setup	Tool software per monitoraggio, lettura e configurazione Itron ACE Pilot Utility Software
Installazione	Etichette per rapporti TA e TV Kit per sigillatura
Documentazione	Certificato di test Manuale d'uso ed installazione

Dimensioni

